



1. This pattern is originally scratch build based on many references and may not perfect yet so I would very appreciate for your critics and advices to improve my design on the next project.  
2. This pattern is not for commercial purposes, except for educational. For other purposes, you may contact me for permission.

**TEKZ\_8@YAHOO.COM**  
**MYHOBBYCRAFT.BLOGSPOT.COM**

The Chance Vought F4U Corsair was a carrier-capable fighter aircraft that saw service primarily in World War II and the Korean War. Goodyear-built Corsairs were designated FG and Brewster-built aircraft F3A. The Corsair served in smaller air forces until the 1960s, following the longest production run of any piston-engined fighter in U.S. history (1942–1952). Some Japanese pilots regarded it as the most formidable American fighter of World War II. The U.S. Navy counted an 11:1 kill ratio with the F4U Corsair.

Corsairs served with the U.S. Navy, U.S. Marines, Fleet Air Arm and the Royal New Zealand Air Force, as well the French Navy Aeronavale and other services postwar. It quickly became the most capable carrier-based fighter-bomber of World War II. Demand for the aircraft soon overwhelmed Vought's manufacturing capability, resulting in production by Goodyear (as the FG-1) and Brewster (as the F3A-1). From the first prototype delivery to the U.S. Navy in 1940, to final delivery in 1953 to the French, 12,571 F4U Corsairs were manufactured by Vought, in 16 separate models.

[en.wikipedia.org](http://en.wikipedia.org)

Use 150-200 gsm paper for pattern and 2mm thick hardpaper for base landing deck

1. This pattern is originally scratch build based on many references and may not perfect yet so I would very appreciate for your critics and advices to improve my design on the next project.  
2. This pattern is not for commercial purposes, except for educational. For other purposes, you may contact me for permission.

**TEKZ\_8@YAHOO.COM**  
**MYHOBBYCRAFT.BLOGSPOT.COM**



1. This pattern is originally scratch build based on many references and may not perfect yet so I would very appreciate for your critics and advices to improve my design on the next project.  
2. This pattern is not for commercial purposes, except for educational. For other purposes, you may contact me for permission.

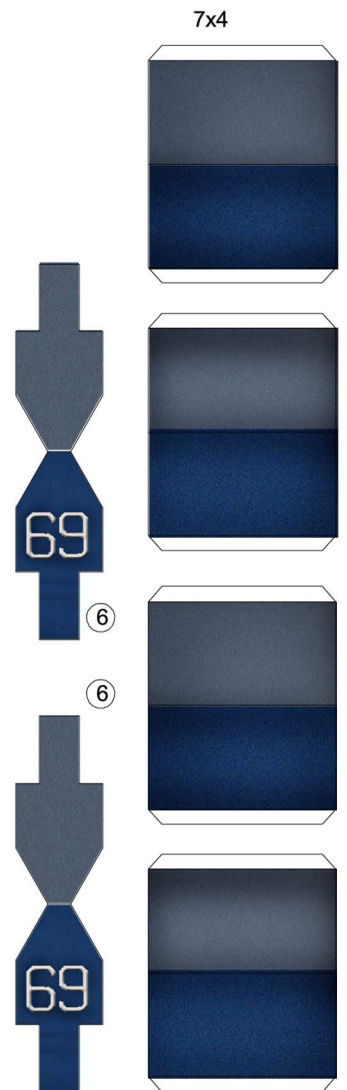
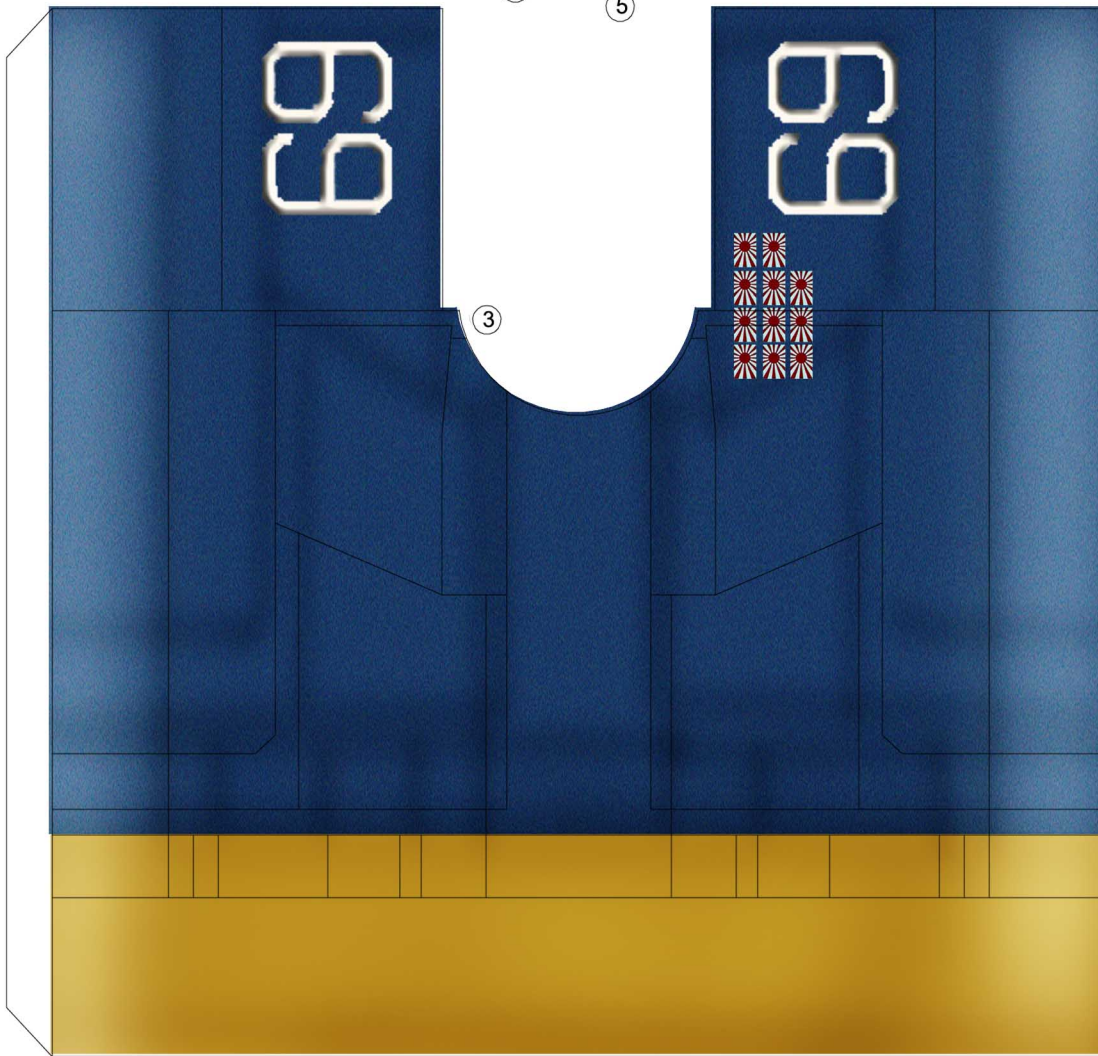
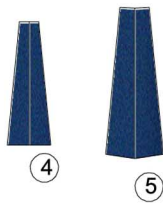
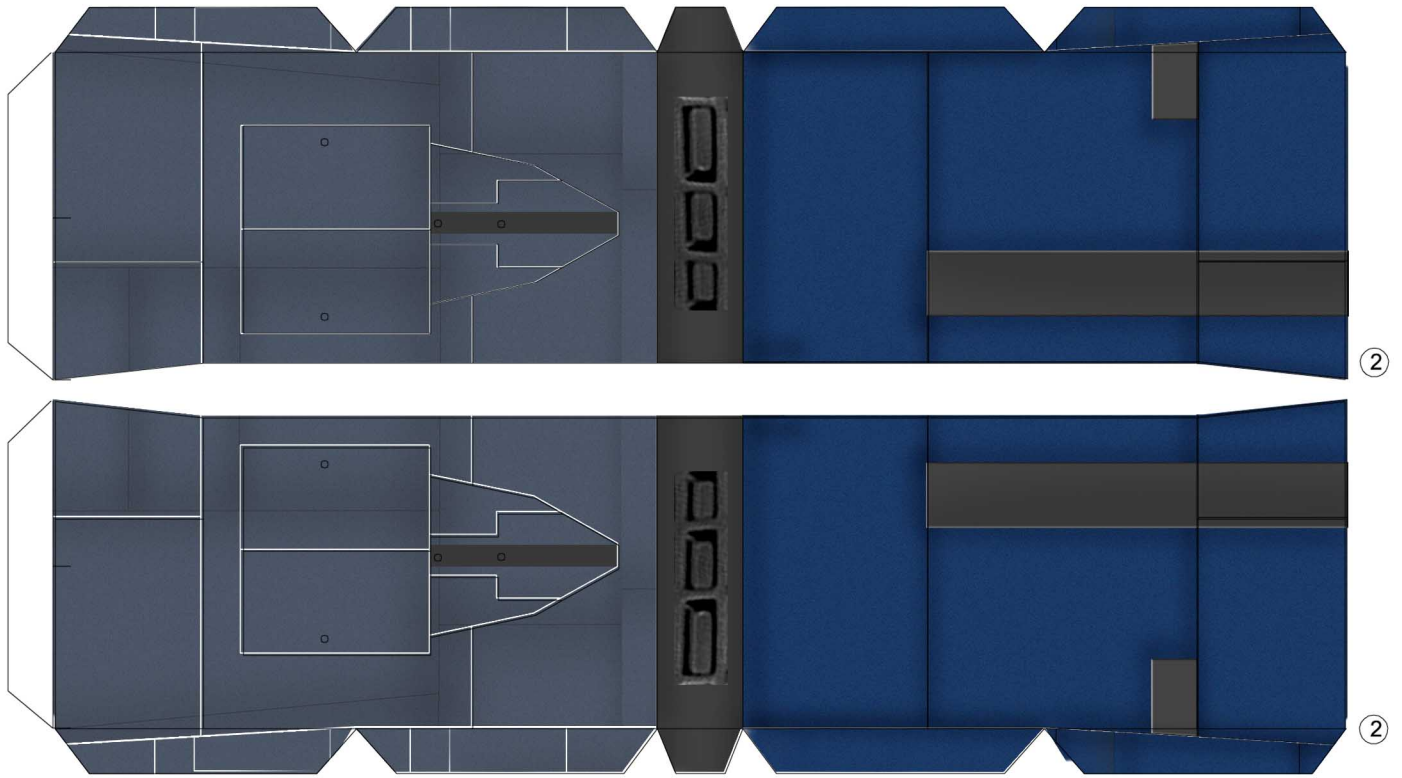

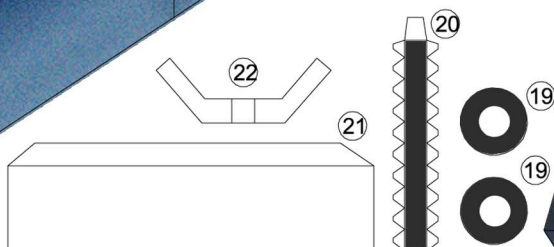
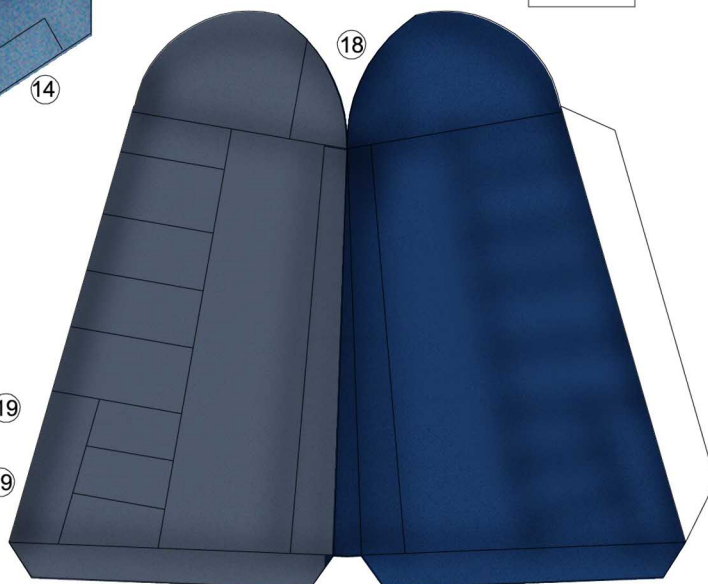
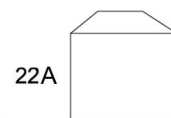
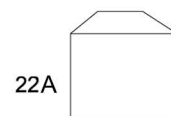
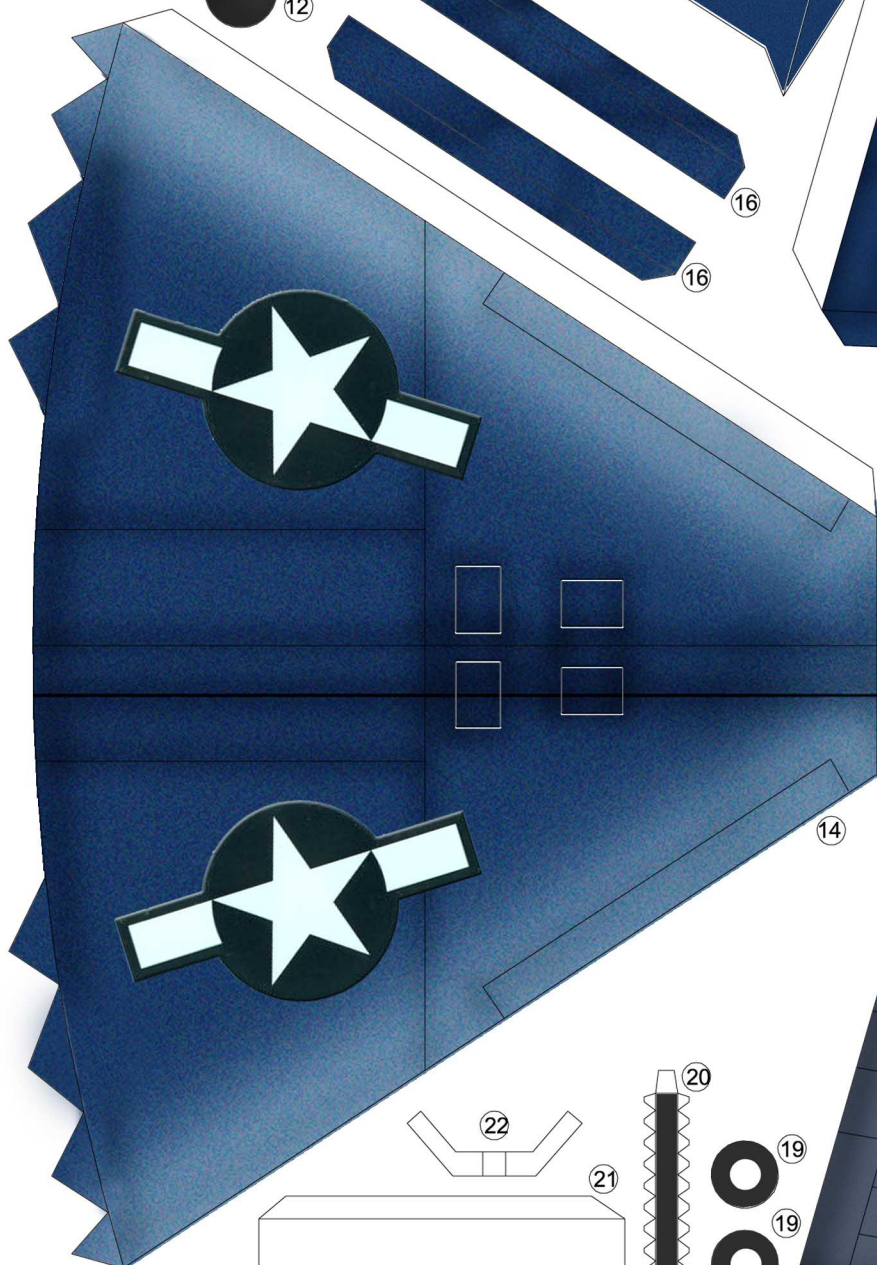
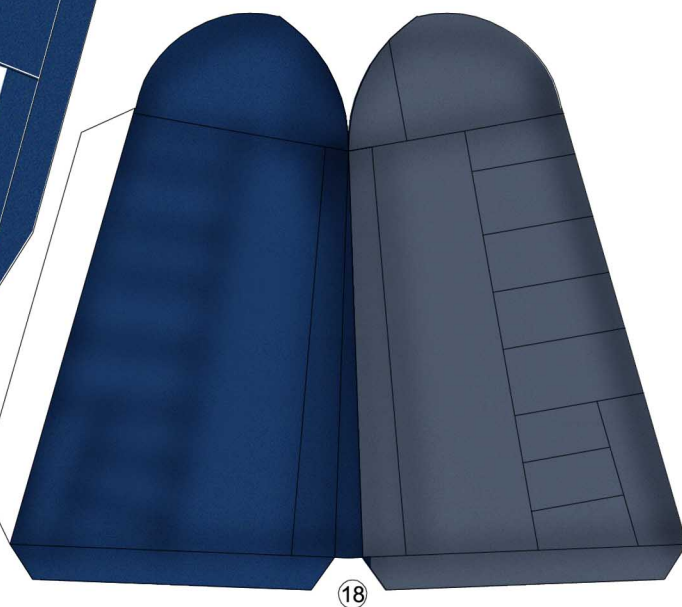
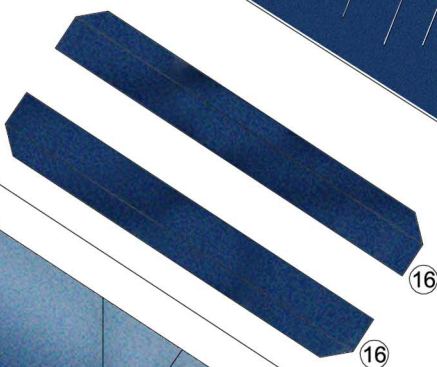
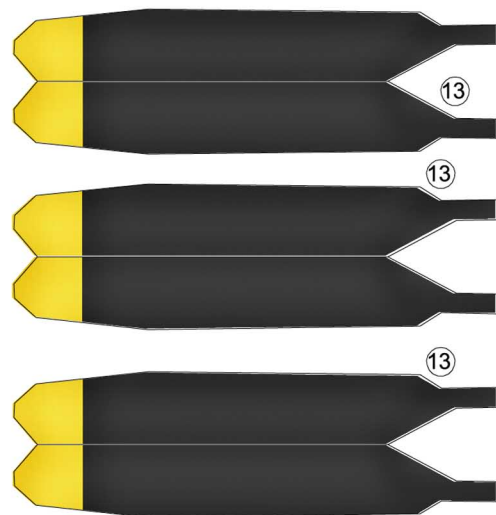
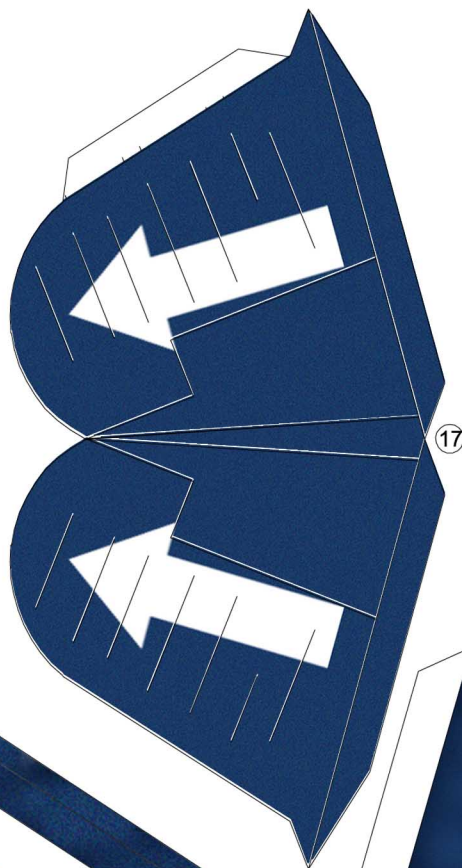
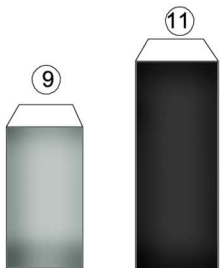
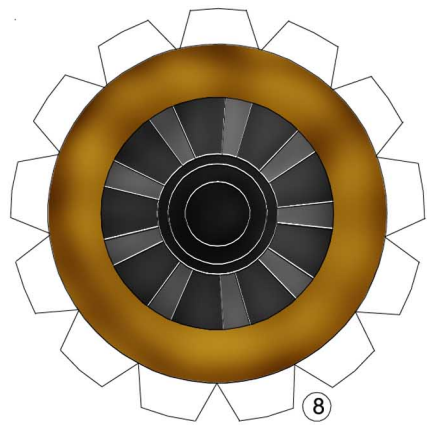

# VOUGHT F4U-1D CORSAIR WITH MOTO-TUG 1/35

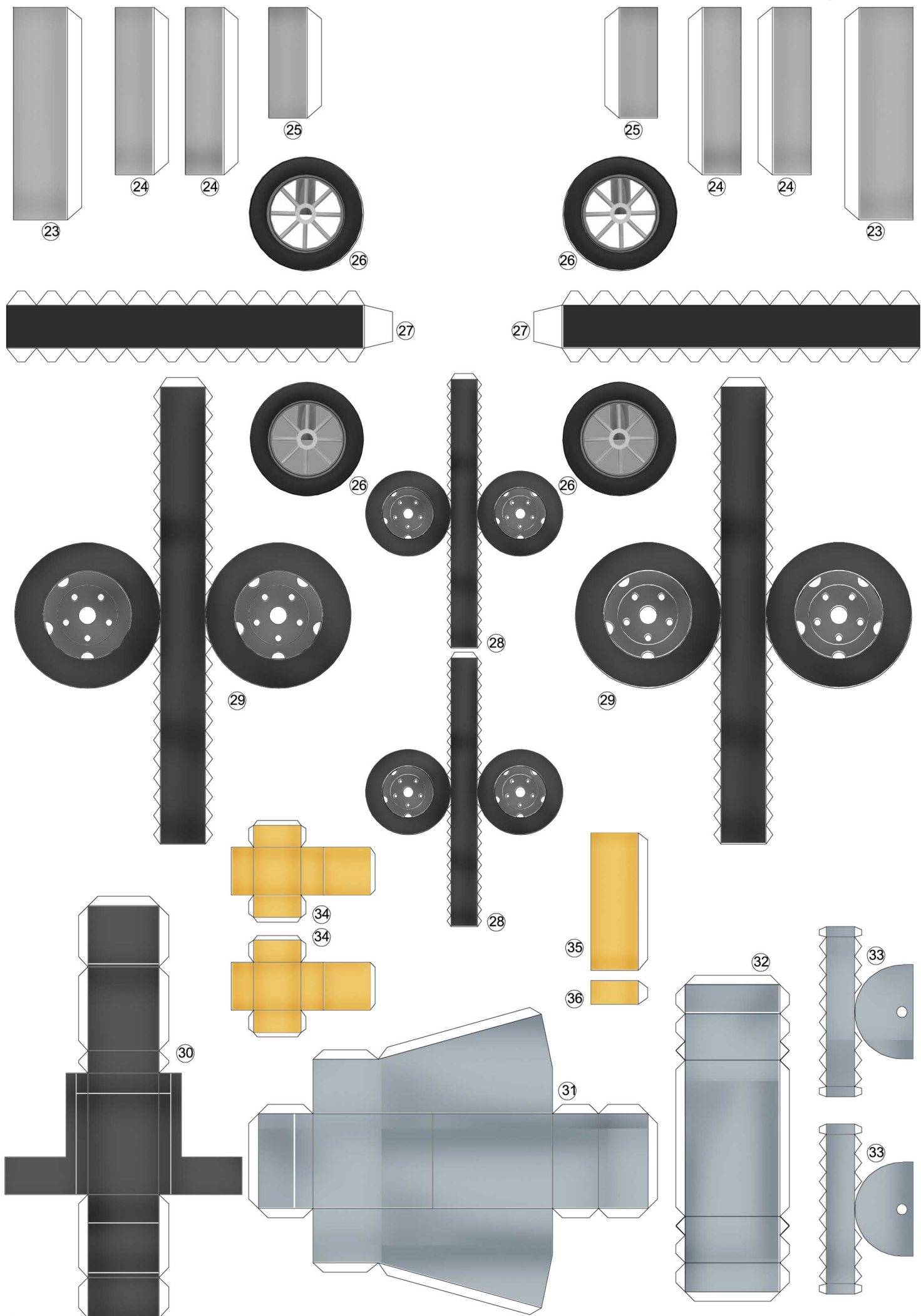

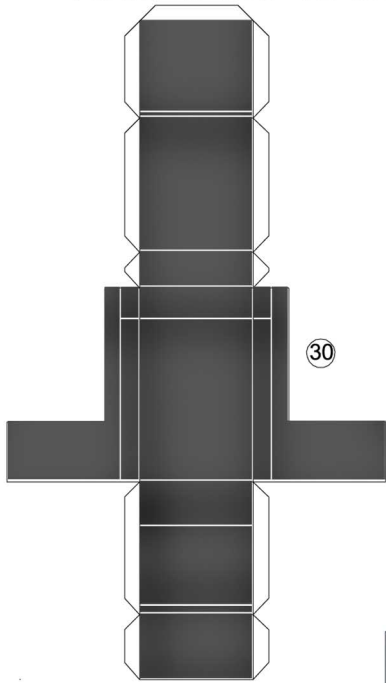

30

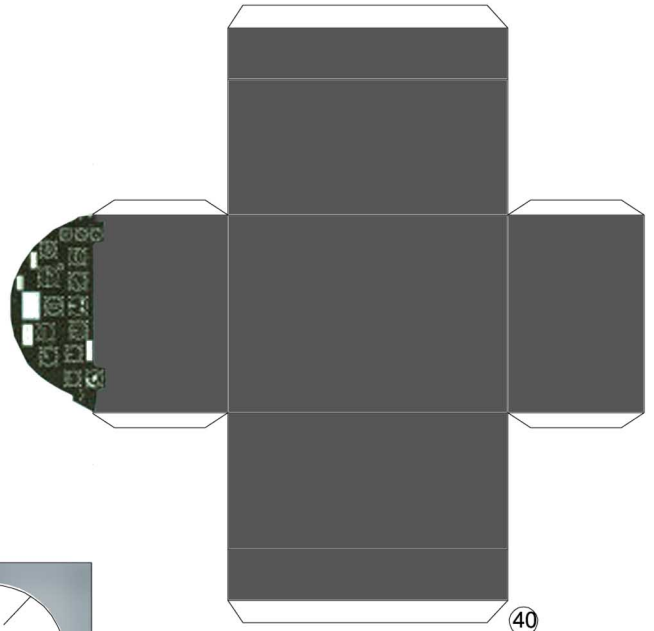
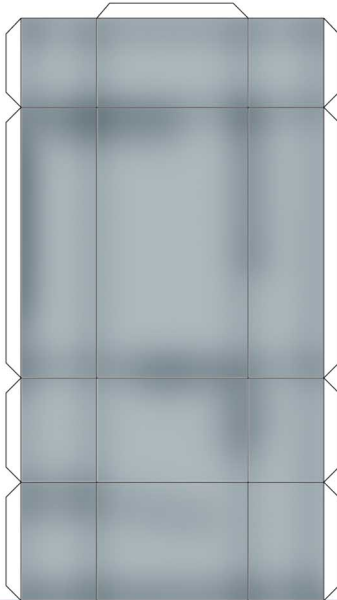

40

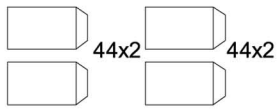

44x2

44x2

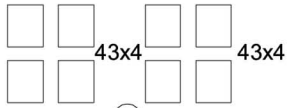

43x4

43x4

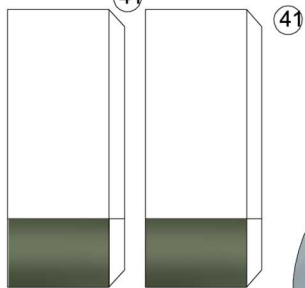

41

41



42

42

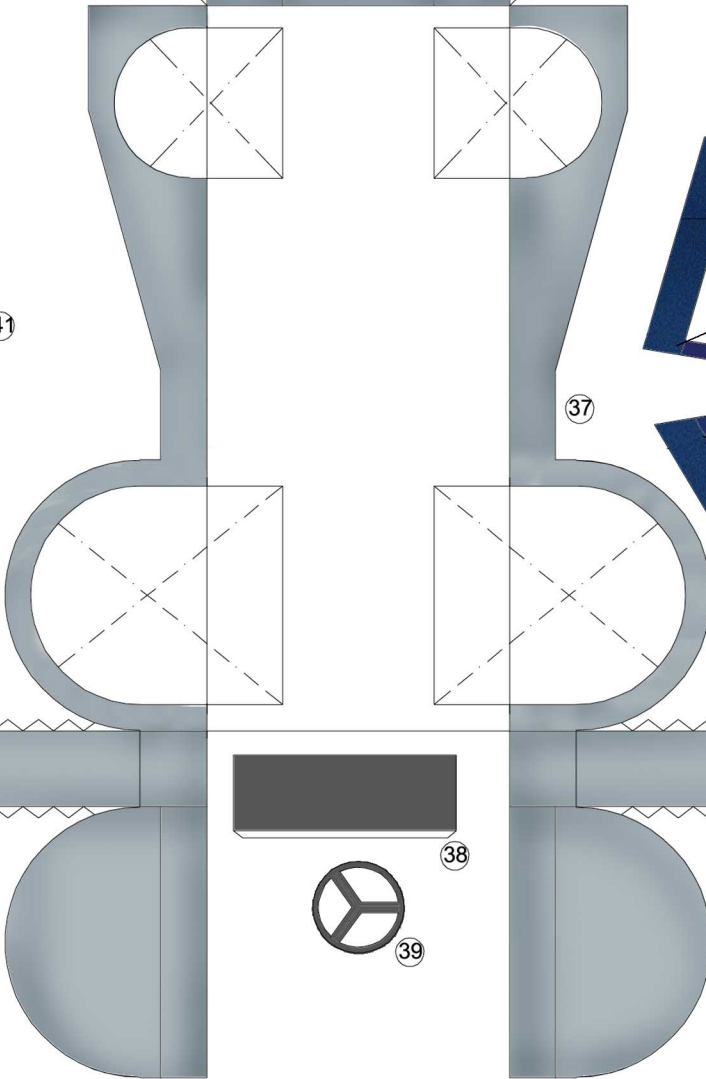

37

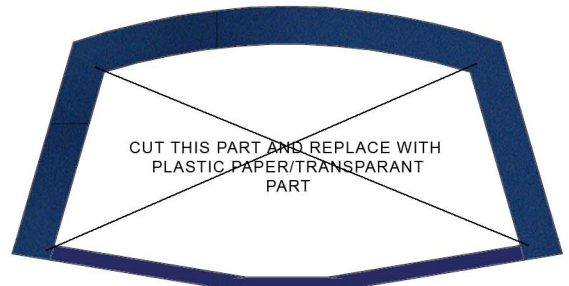

CUT THIS PART AND REPLACE WITH PLASTIC PAPER/TRANSPARENT PART

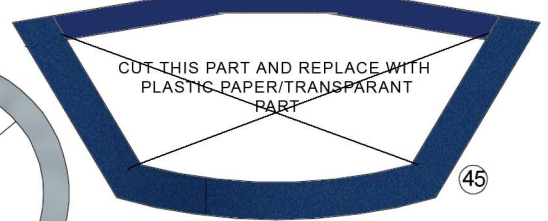

CUT THIS PART AND REPLACE WITH PLASTIC PAPER/TRANSPARENT PART

45

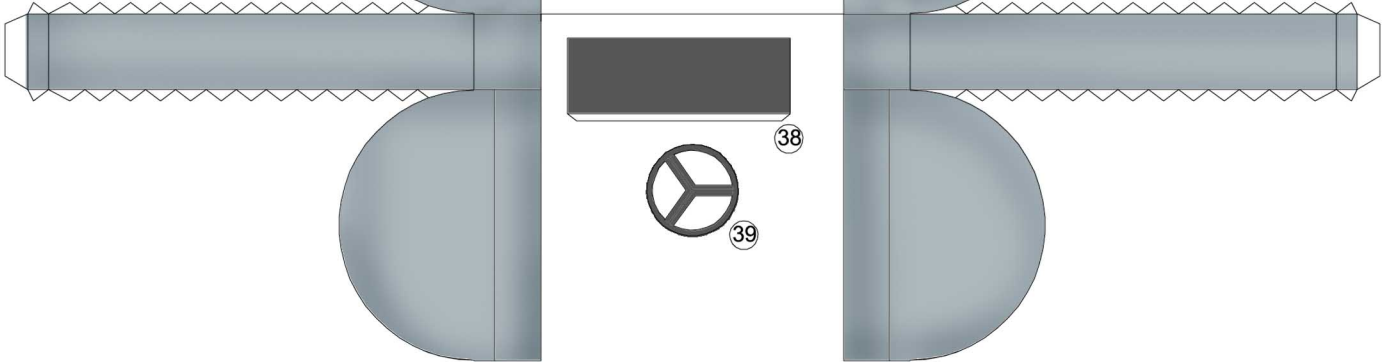

38



39

